

## Association among Dyspnea and the Degrees of Diastolic Dysfunction at Echocardiography

Martha Beatriz de Souza Tavares Passos, Isabelle Sasso Teixeira, Paulo Henrique Botan Medeiros Bortolon, Carlos Eduardo Carniel Beltrami, Ana Cristina Camarozano

Hospital de Clínicas da Universidade Federal do Paraná, Curitiba, Paraná - Brazil

### Summary

**Introduction:** The left ventricle diastolic dysfunction (LVDD) can lead to heart failure with preserved ejection fraction. Echocardiography, especially the tissue Doppler, is the main exam. The clinic has dyspnea as a typical symptom, which is evaluated by modified Medical Research Council (mMRC). However, there are few studies that investigate what is the association between the symptom and LVDD.

**Objective:** Evaluate if dyspnea is associated with the advancement of LVDD and if there is a linkage between mMRC and the degrees of LVDD.

**Method:** Case-control transversal study, with 60 participants, with clinical (mMRC) and echocardiographic (bidimensional parameters, spectral and tissue Doppler) evaluation. Among the participants, 49 constituted the case group (LVDD with dyspnea) and 11 the control group (LVDD without dyspnea). Participants with co-morbidity or other echocardiographic abnormalities related to dyspnea were excluded.

**Results:** The average age was 61,7 ( $\pm$  7,9) years and 72% were women. In overall, 82% of the participants had dyspnea. Among them, 82% had LVDD degree I. All of the study population had preserved ventricular systolic function. The presence of dyspnea was associated with the degree of LVDD ( $p = 0,04$ ), however, the symptom severity was not ( $p = 0,72$ ).

**Conclusion:** Dyspnea was associated with the degree of LVDD, but there was no association between the symptom severity and the evolution of LVDD. The aging, the increase of left atrium and coronary artery disease were associated with the advanced grades of LVDD. (Arq Bras Cardiol: Imagem cardiovasc. 2018;31(2):82-89)

**Keywords:** Heart Failure; Stroke Volume; Dyspnea/complications; Ventricular Dysfunction; Echocardiography, Doppler.

### Introduction

The heart is a structure formed by two serial pumping systems running two phases in the same cycle: systole and diastole. When these phases have their performance affected by any factors, they determine the onset of dysfunction.<sup>1</sup>

In the case of left ventricular diastolic dysfunction (LVDD), it is known that factors such as aging, gender, obesity, systemic arterial hypertension (SAH), diabetes mellitus (DM), coronary artery disease (CAD), left ventricular hypertrophy and atrial fibrillation have an important role in its pathophysiology, thus determining the impairment of relaxation and/or increase in left ventricular (LV) stiffness. Elevation in cardiac filling pressure and left atrial (LA) size may occur, however, without affecting the left ventricular ejection fraction (LVEF) – characteristics of

LVDD with preserved LVEF. Such functional abnormality may result in the clinical syndrome of heart failure with preserved ejection fraction (HFPEF), diagnosed by the simultaneous presence of three criteria: normal ( $\geq 50\%$ ) or subtly reduced LVEF; signs or symptoms of heart failure (HF); and abnormal LV relaxation and/or filling (diastolic dysfunction).<sup>2-4</sup>

The symptoms associated with HF are defined by the Framingham criteria, among which dyspnea (subjective experience of respiratory discomfort) is a relevant parameter. To assess the symptom, the Modified Medical Research Council (mMRC) scale can be used. The questionnaire is simple, easy to apply and highly employable in the routine of medical clinic history.<sup>5,6</sup>

Cardiologic imaging can be done using Doppler echocardiography, which is considered a gold standard for the evaluation of LVDD, as it is a non-invasive, radiation-free, fast and portable test.<sup>7</sup>

By analyzing the echocardiographic parameters, diastolic dysfunction can be divided into three stages – slow relaxation (grade I), pseudonormal relaxation (grade II) and restrictive pattern (grade III).<sup>8</sup> In grade I, there is a deficit of LV myocardial relaxation, determining a lower pressure gradient in the fast filling phase, as well as an acceleration of transmitral flow to this chamber, without affecting left atrial pressure (LAP).

**Mailing Address:** Martha Beatriz de Souza Tavares Passos •  
Hospital de Clínicas da Universidade Federal do Paraná  
R. Gen. Carneiro, 181. Postal Code 80060-900, Alto da Glória, Curitiba,  
PR – Brazil  
E-mail: marthabia@gmail.com  
Manuscript received December 18, 2017; revised January 14, 2018;  
accepted January 26, 2018

**DOI:** 10.5935/2318-8219.20180011

Grade II, previously considered a pseudonormal pattern, is an intermediate stage of LVDD, in which the transmitral flow is similar to the curve of normal patients. However, there are abnormalities of both relaxation and restrictive forces, but the abnormalities are somehow balanced – compared to mitral flow analysis, whereas there are detectable abnormalities in tissue Doppler. Grade III, on the other hand, is characterized by more significant abnormalities in ventricular complacency than in its relaxation, being considered a restrictive pattern. Due to this set of abnormalities, there is a greater transmitral pressure gradient, as well as an increase in LAP, a manifestation of the restrictive pattern. Considering these abnormalities, echocardiography allows to evaluate diastolic function and intracavitary filling pressures which, when increased – due to increased ventricular stiffness – correspond to the evolution of LVDD.<sup>9</sup>

Although dyspnea is part of the Framingham diagnostic criteria, the relationship between the symptom and the LVDD still raises controversy, in addition to the fact that few studies specifically evaluate the association between dyspnea stratification and LVDD grades.

## Objective

The objective of this study was to assess whether dyspnea is associated with the presence of LVDD at echocardiography, clarifying whether there is a relationship between the classification of mMRC of dyspnea and LVDD grade. As a secondary outcome, the study determines whether there is an association between more advanced degrees of LVDD with other clinical factors, as well as similar echocardiographic parameters.

## Methods

This study has been approved by the Research Ethics Commission of Hospital de Clínicas (HC) da Universidade Federal do Paraná (UFPR).

A cross-sectional case-control study with data collection from February to August 2017 has been conducted. Patients from the Echocardiography Service of HC- UFPR were evaluated. The case group consisted of individuals with LVDD at echocardiography reporting dyspnea; and the control group, by individuals with LVDD at echocardiography, not reporting dyspnea.

The inclusion criteria were: accepting to participate in the study, by signing the Informed Consent Term; having LVED at echocardiography; be between 18 and 75 years of age; have preserved LVEF and absence of comorbidities associated with dyspnea, such as pulmonary, valvular or neurological disease, left ventricular systolic dysfunction and abnormal right chambers or pulmonary hypertension.

Sixteen participants were excluded from the study: eight due to decreased LVEF; two for refusing to sign the informed consent; two due to moderate to severe asthma; one for presenting cardiac arrhythmia during the test; one due to increased right chamber; one due to moderate aortic and tricuspid insufficiency; and one due to echocardiography scans with no defined information on abnormal diastolic function.

Considering these criteria, an active search of the participants was performed through the echocardiography

test booking system of Hospital de Clínicas. The clinical data collected were provided by the participants. The reports analyzed were prepared by the physicians of the echocardiography service, so the researchers did not attend to the test and did not help preparing the report – a characteristic of the service in question.

After analyzing the echocardiographic reports, the medical records of each of the participants were analyzed in order to confirm the clinical data informed by the patients when the informed consent was applied.

## Dyspnea

To assess the reports of dyspnea, the mMRC scale was employed during recruitment for the study. The scale evaluates the presence of dyspnea on major, medium and small exertion,<sup>5</sup> according to Chart 1.

From grades 1 to 4, two groups were made: group A, characterized by dyspnea on major and medium exertion, (mMRC 1 and 2); and group B, with dyspnea on minor exertion and at rest (mMRC 3 and 4).<sup>5</sup> These groups, as well as the control group, were divided according to the grade of LVDD, as shown in Figure 1.

## Electrocardiography

All echocardiography scans were performed on ultrasound scanner Phillips Affiniti 50®. The scans, classification of the grades of diastolic dysfunction and the reports were performed by the physicians of the HC Echocardiography Service, who used tissue Doppler and other echocardiographic parameters recommended in the 2016 guideline for the evaluation of left ventricular diastolic function of the American Society of Echocardiography and the European Association of Echocardiography,<sup>4</sup> to determine the grade of diastolic dysfunction. Doppler (two-dimensional, spectral and tissue) scans of the LV structural and functional conditions considered the following parameters: LV filling pressure; mitral flow analysis; peak E-wave velocity; peak A-wave speed; E/A ratio; E/e' ratio; tricuspid regurgitation velocity; LA volume and pressure; and pulmonary vein flow.<sup>4,7</sup> The researchers were solely in charge of reading and analyzing the data contained in the report.

## Biostatistics

Statistical analysis was expressed as mean, standard deviation or percentage, as required. Inferential statistics of data adopted a level of significance of 5% ( $p \leq 0.05$ ). To associate the qualitative variables, Fisher's exact test and the chi-squared test were used; to associate the quantitative variables, Student's t test was used. All data were analyzed using the software Minitab version 17.

## Results

The study population consisted of 49 participants in the case group (with dyspnea) and 11 in the control group (without dyspnea). The mean age was 61.77 ( $\pm 7.97$ ), 43 participants (72%) were female, and 51 participants (85%) had grade I LVDD.

Chart 1 – mMRC dyspnea scale

Grade	Defining characteristics
0	Dyspnea only with strenuous exercise
1	Dyspnea when hurrying or walking up a slight hill
2	Walks slower than people of the same age because of dyspnea or has to stop for breath when walking at own pace
3	Stops for breath after walking 100 meters or after a few minutes
4	Too dyspneic to leave house or breathless when dressing

Source: Adapted from Yawn et al.,<sup>5</sup> 2017.

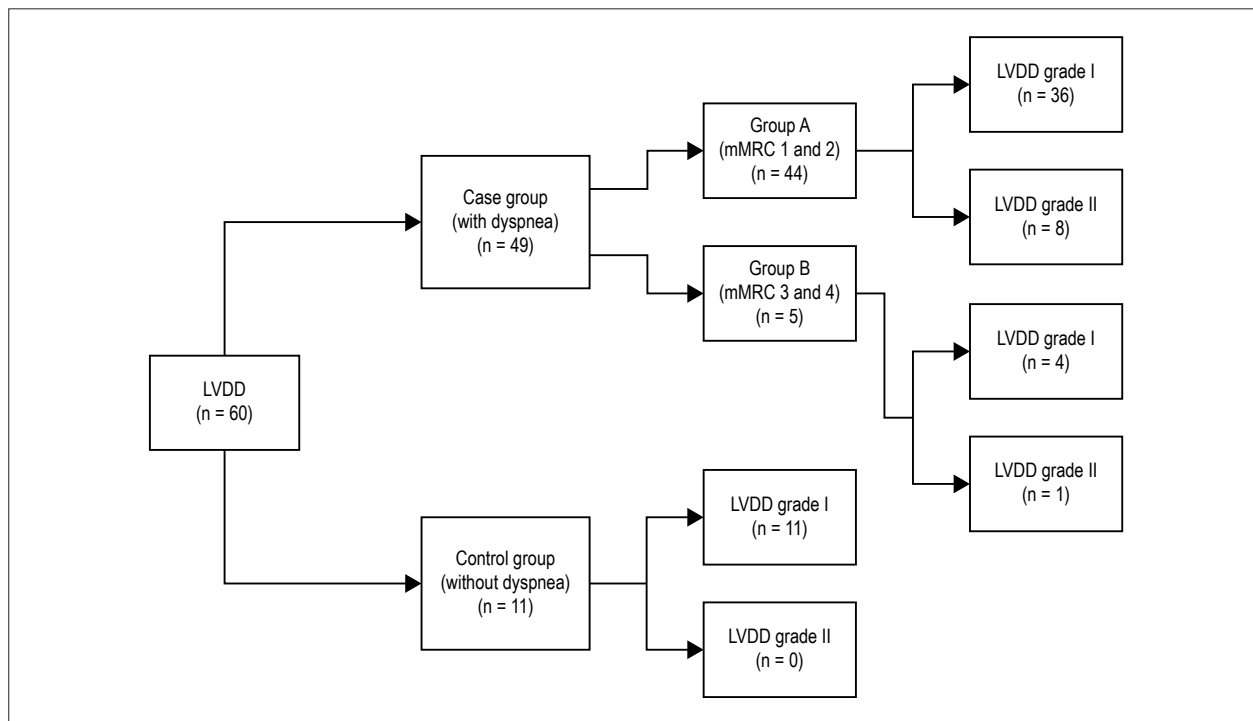

Figure 1 – Flowchart of the Groups Evaluated; n: sample space of each group.

Of the symptomatic patients, 34 participants were from mMRC 1 (70%), 10 from mMRC 2 (20%), 3 from mMRC 3 (6%) and 2 from mMRC 4 (4%). Also considering the case group, 40 participants (82%) presented grade I LVDD and 9 (18%) presented grade II LVDD. Of the asymptomatic patients, all 11 participants had grade I LVDD. None of the participants had grade III LVDD. From this quantification, an association was established between the presence of dyspnea and the LVDD grade ( $p = 0.04$ ), using the absolute frequencies of each variable, according to Chart 1.

Despite the positive association demonstrated above, dyspnea groups A and B, when associated with LVDD grades I and II (Chart 2), did not present the same pattern of significance ( $p = 0.72$ ).

The observed frequencies of clinical parameters in the study population are described in Table 1. These parameters were associated with the grades of LVDD. The presence

of SAH had no positive association with the grades of LVDD ( $p = 0.58$ ) or with DM ( $p = 0.72$ ) and dyslipidemia ( $p = 0.29$ ). However, the presence of CAD was significant in the population with LVDD ( $p = 0.04$ ).

Considering the grades of LVDD and the age of the patients, there was no association between the different grades of LVDD and older age ( $p = 0.06$ ).

The mean BMI of the participants was  $30.01 (\pm 4.51)$ . The association between this variable and the grades of LVDD was not significant – neither in the direct evaluation with the BMI values of each participant nor with the classification of BMI according to the World Health Organization (WHO)<sup>10</sup> ( $p = 0.77$  and  $p = 0.75$ , respectively).

The echocardiographic parameters are described in Table 2. Only 13% of the reports collected contained the description of the E/e' ratio calculation, so this parameter was not considered in the analysis.

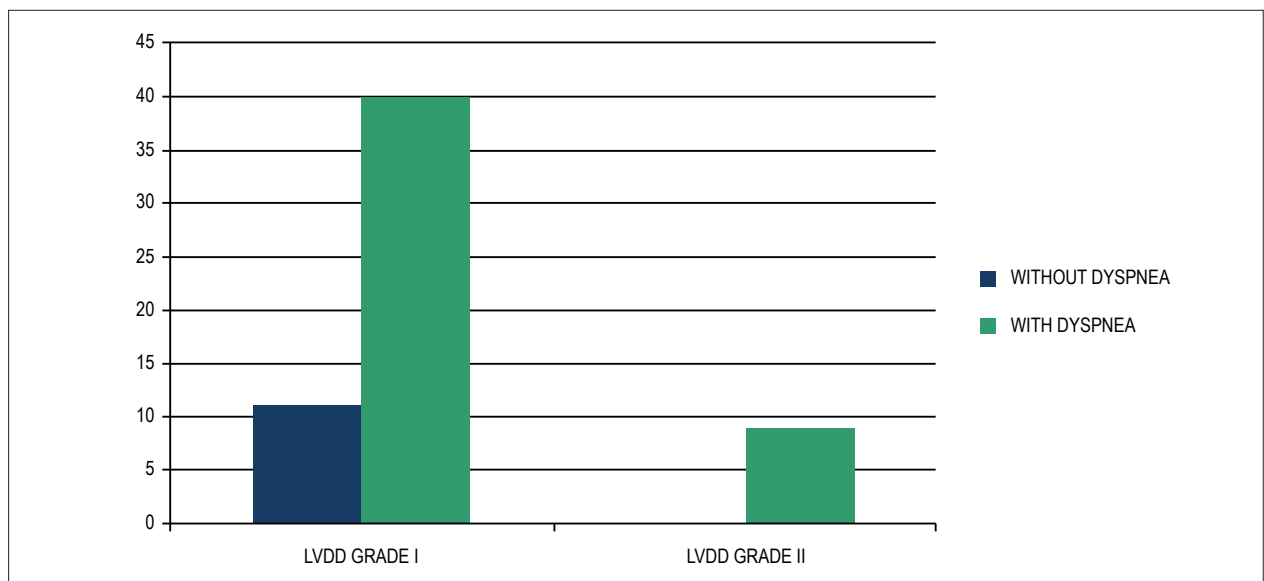

**Chart 1** – Association between the degree of diastolic dysfunction and presence of dyspnea. LVDD: left ventricular diastolic dysfunction.

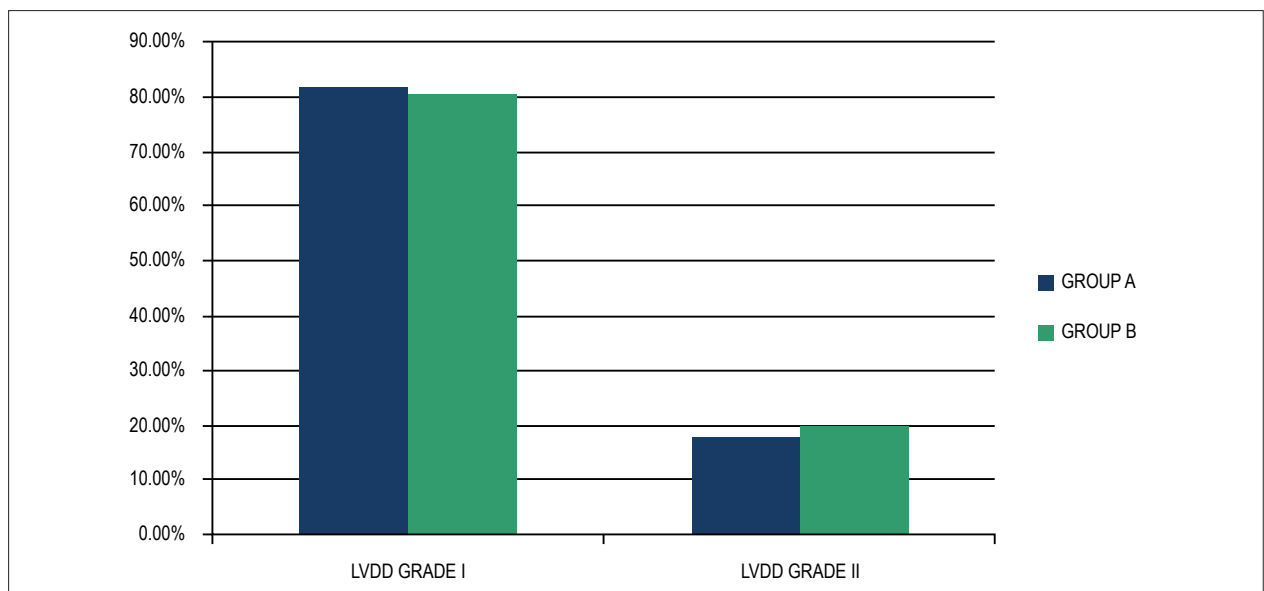

**Chart 2** – Association between the degree of diastolic dysfunction and dyspnea groups. LVDD: left ventricular diastolic dysfunction.

All participants had preserved LVEF, which was associated with grades of LVDD, but was not statistically significant ( $p = 0.88$ ).

Comparing the LA size between the case and control groups, no significant difference was observed ( $p = 0.99$ ).

The grade of LVDD was positively associated with increased LA ( $p = 0.0019$ ), as shown in Chart 3.

## Discussion

The demographic data of this study show a predominance of females (72%), with mean age 61.7 years, mean BMI 30.01 kg/m<sup>2</sup> and hypertension (88%). Other comorbidities,

such as: DM (47%), CAD (28%) and dyslipidemia (60%) were also frequent in the subgroup studied. All participants had preserved LVDD and LVEF, according to the criteria adopted by the American Society of Echocardiography and The European Association of Cardiovascular Imaging.<sup>4</sup> Dyspnea was observed in 82% of the patients. This epidemiological profile is shown to be expected for individuals with HFPEF and older.<sup>2</sup>

The association between the grades of LVDD and the presence or absence of dyspnea was statistically significant, that is, there was a relationship between the presence of dyspnea and more advanced grades of LVDD – as reported in the literature.<sup>11,12</sup> That is, patients with more severe LVDD can be expected to have the symptom.

**Table 1 – Clinical parameters**

Parameters	General population		Symptomatic		Asymptomatic	
	n	%	n	%	n	%
SAH	53	88	42	86	11	100
DM	28	47	21	43	7	64
CAD	17	28	15	31	2	18
DSLPL	36	60	30	61	6	54

n: absolute frequency; %: relative frequency; SAH: systemic arterial hypertension; DM: diabetes mellitus; CAD: coronary artery disease; DSLPL: dyslipidemia.

**Table 2 – Echocardiographic parameters**

Parameters	General population	Symptomatic	Asymptomatic
LVEF (%)	71.16 ± 5.06	70.51 ± 4.51	74.02 ± 6.51
LA (mm)	38.75 ± 4.27	38.75 ± 4.20	38.72 ± 4.77
LV diastolic diameter (mm)	46.13 ± 3.16	46.08 ± 3.09	46.36 ± 3.58
LV systolic diameter (mm)	27.42 ± 2.85	27.65 ± 2.69	26.36 ± 3.41

LVEF: left ventricular ejection fraction; LA:left atrium; LV: left ventricle.

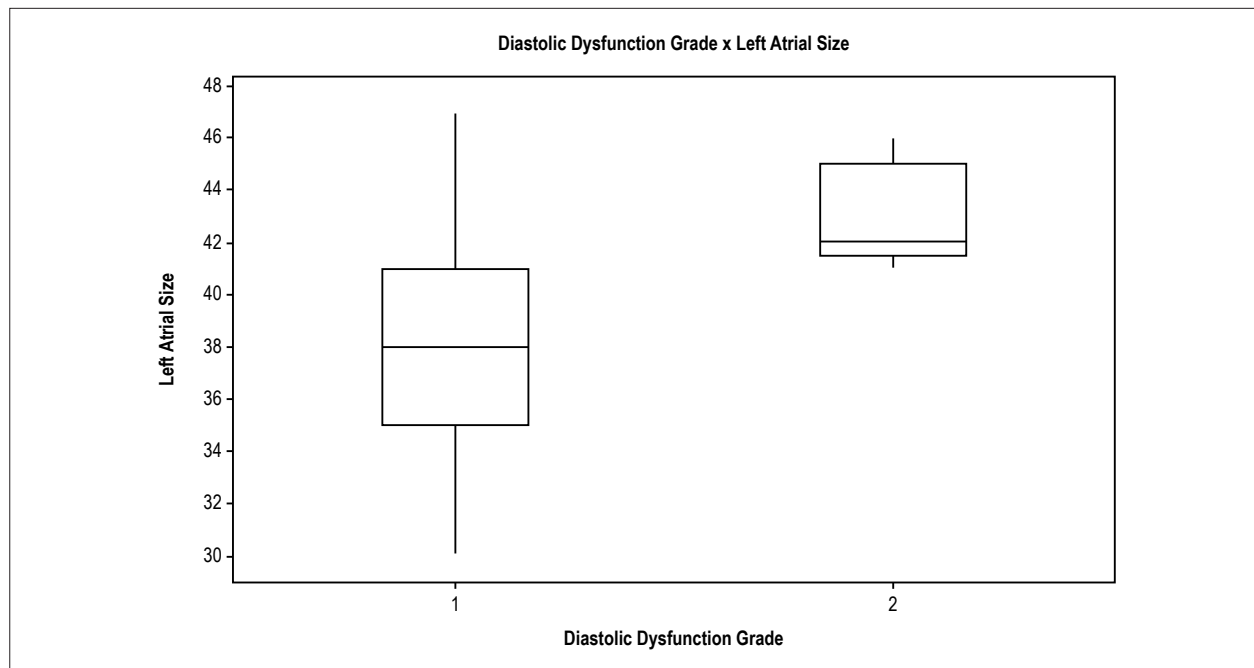

**Chart 3 – Association between LVDD and LA size.**

It was observed that patients with dyspnea from both group A and group B had a higher proportion of grade I LVDD, showing no linear relationship between the degree of dyspnea and the grade of LVDD – that is, patients with advanced grade LVDD cannot be expected to have dyspnea in its most severe form. However, the comparison between the case and control groups was statistically significant because it showed that no participant in the control (asymptomatic) group presented grade II LVDD,

while 18% of the case group (symptomatic) presented it. The studies of Nasim et al.,<sup>11</sup> 2013 and Farag et al.,<sup>13</sup> 2017, who used the Borg scale and functional evaluations to determine the symptom of dyspnea, corroborate the outcome of the relationship between the presence of dyspnea and the evolution of LVDD.<sup>9</sup> However, both found positive results of the association between symptom progression and the progression of LVDD,<sup>11,13</sup> unlike what was found in this study.

It was not possible to differentiate LVDD according to LVEF, in addition to what is reported in the literature.<sup>2,8</sup> However, the study design did not have this objective, since only participants with preserved LVEF were included, to guarantee greater accuracy in the evaluation of HFPEF in the study population.

It is known that age is related to changes in diastolic parameters of mitral velocity and flow, reduction of LV complacency and LA dilation. As aging is considered an independent determinant, a relationship between the progression of LVDD and older age is expected. In this study, whose participants were between 43 and 75 years of age, this association was not observed. However, the populations described in the literature present an older mean age than the mean of this study (61.7 years), which may have statistically strengthened the importance of age in the pathophysiology of LVDD in those reports.<sup>7,14</sup>

Regarding BMI, there was no significant difference between the grades of LVDD, regarding neither the individual values obtained nor the classification of BMI according to the WHO.<sup>10</sup> Despite such considerations, it is necessary to consider that ethnicity and age interfere with BMI and may interfere in the relationship with LVDD. Therefore, a more thorough evaluation is necessary to correct these factors and establish the role of BMI in the grade of LVDD.<sup>15,16</sup>

The presence of CAD was significant in the population with LVDD, but it is not possible to classify it as an independent risk factor for this population, since the presence of CAD was observed from the medical history of the participants. Other studies, however, performed laboratory and imaging tests to evaluate the same association, which is controversial.<sup>17,18</sup>

Although the E/e' ratio is recommended in the evaluation of diastolic function, this parameter was not used in this study due to its low incidence (13%) among the reports collected. The E/e' ratio is one of the numerical parameters of diastolic function evaluation, and it is a consensus among professionals in the HC Echocardiography laboratory to define the grade of LVDD according to the algorithm of the American Society of Echocardiography and the European Association of Echocardiography,<sup>4</sup> although said relationship is not described in all reports. Therefore, other parameters were evaluated in this study, including the LA dimension, which is one of the well-established echocardiographic parameters for LVDD. The dilatation of this chamber reflects the evolution of LVDD by the decrease of ventricular complacency and chronic exposure to high filling pressures. This dimension tends to increase with the progression of LVDD, as the one found.<sup>4,7,19</sup> Therefore, it can be inferred that in the absence of tissue Doppler and other factors that increase LA, the analysis of the mitral flow associated with increased LA can corroborate the prediction of more advanced grades of LVDD, denoting increased intracavitary filling pressures.

In addition to that, the LA size was not positively associated with the presence of dyspnea in participants with LVDD. According to Ratanasit et al.,<sup>20</sup> who used an exercise test to assess dyspnea, atrial dilatation ( $43 \pm 6.1$ ) can predict lower

tolerance to exercise.<sup>20</sup> However, this investigation of dyspnea was based only on clinical criteria (mMRC) and no significant difference was found between the LA dimensions of the case and control groups.

### Limitations

To avoid sample selection bias, this study had a heterogeneous and limited population (60 participants). It had a small population in group B of dyspnea, since the echocardiographic data of LVED with preserved LVEF was considered a critical inclusion criterion – which may have interfered with the statistical analysis. On the other hand, this fact better reflects the reality addressed, which was the intention of the study.

Moreover, participants with no LVDD and dyspnea were not recruited because the purpose of this study was to address and evaluate participants with LVDD. Besides, the population served by the HC-UFPR Echocardiography Service hardly involves patients with normal diastolic function. Thus, the research methodology was designed considering the patterns dealt with in the HC.

Another limiting factor was the non-description of the E/e' ratio in the diastolic function evaluation reports. However, defining the LVDD grade according to the algorithm of the American Society of Echocardiography and the European Association of Echocardiography is a consensus among HC echocardiography laboratory team.<sup>4</sup> That is, the E/e' ratio is calculated to classify LVDD grade, but is not described in all reports.

### Suggestions

Considering the study limitations, it is recommended that new approaches be carried out with the same objective, including longitudinal evaluation in a larger and more homogeneous group. In addition, it is interesting that dyspnea be evaluated with more clinical parameters to strengthen its relationship with HFPEF.

It is worth noting that for echocardiography services without access to tissue Doppler, it is suggested to evaluate the evolution of LVDD by left atrial size, in the absence of other factors that may increase it.

### Conclusion

Dyspnea was very prevalent in the population with diastolic dysfunction, demonstrating an association between the presence of the symptom and dysfunction. However, there was no close association between the intensity of dyspnea and more advanced levels of diastolic dysfunction. However, this study demonstrated that the absence of dyspnea seems to be associated with a lower degree of diastolic dysfunction, since no asymptomatic patient had advanced diastolic dysfunction.

Enlarged left atrium and the presence of coronary artery disease were associated with the presence of higher grades of left ventricular diastolic dysfunction.



## Authors' contributions

Research creation and design: Teixeira IS, Passos MBST, Camarozano AC; Data acquisition: Teixeira IS, Passos MBST, Bortolon PHBM, Beltrami CEC, Camarozano AC; Data analysis and interpretation: Teixeira IS, Passos MBST, Bortolon PHBM, Beltrami CEC, Camarozano AC; Statistical analysis: Teixeira IS, Passos MBST, Camarozano AC; Manuscript drafting: Teixeira IS, Passos MBST; Critical revision of the manuscript for important intellectual content: Teixeira IS, Passos MBST, Camarozano AC.

## References

1. Guyton AC, Hall JE, Guyton AC. Tratado de fisiologia médica: Rio de Janeiro: Editora Elsevier; 2006.
2. Miljkovic LV, Spiroska V. Heart failure with preserved ejection fraction--concept, pathophysiology, diagnosis and challenges for treatment. *Open access Macedonian J Med Sci.* 2015;3(3):521-7.
3. Bocchi EA, Braga FGM, Ferreira SMA, Rohde LEP, Oliveira WAd, Almeida DRd, et al. III Diretriz brasileira de insuficiência cardíaca crônica. *Arq Bras Cardiol.* 93(1 supl):1-71.
4. Nagueh SF, Smiseth OA, Appleton CP, Byrd BF, Dokainish H, Edvardsen T, et al. Recommendations for the evaluation of left ventricular diastolic function by echocardiography: an update from the American Society of Echocardiography and the European Association of Cardiovascular Imaging. *Eur Heart J Cardiovasc Imaging.* 2016;17(12):1321-60.
5. Yawn BBP, Thomashaw B, Mannino DM, Han MK, Kalhan R, Rennard S, et al. The 2017 Update to the COPD Foundation COPD Pocket Consultant Guide. *Chronic Obstructive Pulmonary Diseases. Obstr Pulm Dis.* 2017;4(3):177-85.
6. Kasper DL, Fauci AS, Hauser S, Longo DL, Jameson JL, Loscalzo J. *Medicina interna de Harrison.* Porto Alegre: Artmed; 2013.
7. Dugo C, Rigolli M, Rossi A, Whalley GA. Assessment and impact of diastolic function by echocardiography in elderly patients. *J Geriatr Cardiol.* 2016;13(3):252-60.
8. Barbosa MM, Nunes MCP, Campos Filho O, Camarozano A, Rabischoffsky A, Maciel BC, et al.; Sociedade Brasileira de Cardiologia. Diretrizes das indicações da ecocardiografia. *Arq Bras Cardiol.* 2009;93(6 supl 3):e265-e302.
9. Mann DL, Zipes D. *Braunwald tratado de doenças Cardiovasculares.* Rio de Janeiro: Editora Elsevier; 2017.
10. World Health Organization.(WHO). Obesity: preventing and managing the global epidemic: report of a WHO consultation. Washington;2000. (WHO Technical Report Series 894)
11. Nasim S, Nadeem N, Zahidie A, Sharif T. Relationship between exercise induced dyspnea and functional capacity with doppler-derived diastolic function'. *BMC Res Notes.* 2013;6:150.

## Potential Conflicts of Interest

There are no relevant conflicts of interest.

## Sources of Funding

This study had no external funding sources.

## Academic Association

This study is not associated with any graduate programs.

12. Santos M, Kitzman DW, Matsushita K, Loehr L, Sueta CA, Shah AM. Prognostic importance of dyspnea for cardiovascular outcomes and mortality in persons without prevalent cardiopulmonary disease: The Atherosclerosis Risk in Communities Study. *PLoS One.* 2016;11(10):20165111
13. Farag ESM, Al-Daydamony MM, Gad MM. What is the association between left ventricular diastolic dysfunction and 6-minute walk test in hypertensive patients? *J Am Soc Hypertens.* 2017;11(3):158-64.
14. Germing A, Gotzmann M, Schikowski T, Vierkötter A, Ranft U, Krämer U, et al. High frequency of diastolic dysfunction in a population-based cohort of elderly women-but poor association with the symptom dyspnea. *BMC Geriatr.* 2011;11:71.
15. Lee SL, Daimon M, Tullio DMR, Homma S, Nakao T, Kawata T, et al. Relationship of left ventricular diastolic function to obesity and overweight in a Japanese population with preserved left ventricular ejection fraction. *Circ J.* 2016;80(9):1951-6.
16. Russo C, Jin Z, Homma S, Rundek T, Elkind MSV, Sacco RL, et al. Effect of obesity and overweight on left ventricular diastolic function: a community-based study in an elderly cohort. *J Am Coll Cardiol.* 2011;57(12):1368-74.
17. Jamiel A, Ahmed AM, Farah I, Al-Mallah MH. Correlation between diastolic dysfunction and coronary artery disease on coronary computed tomography angiography. *Heart Views.* 2016;17(1):13-8.
18. Lin FY, Zemedkun M, Dunning A, Gomez M, Labounty TM, Asim M, et al. Extent and severity of coronary artery disease by coronary CT angiography is associated with elevated left ventricular diastolic pressures and worsening diastolic function. *J Cardiovasc Comput Tomogr.* 2013;7(5):289-96.
19. Dokainish H. Left ventricular diastolic function and dysfunction: central role of echocardiography. *Glob Cardiol Sci Pract.* 2015 Jan 26;2015:3.
20. Ratanasit N, Karaketklang K, Chirakarnjanakorn S, Krittayaphong R, Jakrapanichakul D. Left atrial volume as an independent predictor of exercise capacity in patients with isolated diastolic dysfunction presented with exertional dyspnea. *Cardiovasc Ultrasound.* 2014 Jun 14;12:19.

